



Date : **Septembre 2021**
 Événement : **CF Brushless**
 Pilote : **BULLE Samuel**

Moteur : **830 KV**
 Embrayage : **/**
 Échappement : **/**
 Différentiel : **FG**
 Carrosserie : **FBX LMP 2**

Piste : **Grenoble RACG**
 Aspect : **Bon**
 Grip : **Très bon**
 Conditions : **Sèche**
 T° Air : **25°**
 Pneus avant : **GRP M2**
 Pneus arrière : **GRP M2**

TRAIN AR

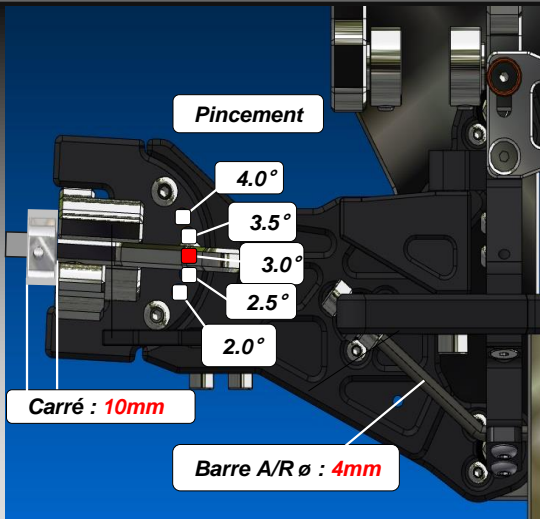
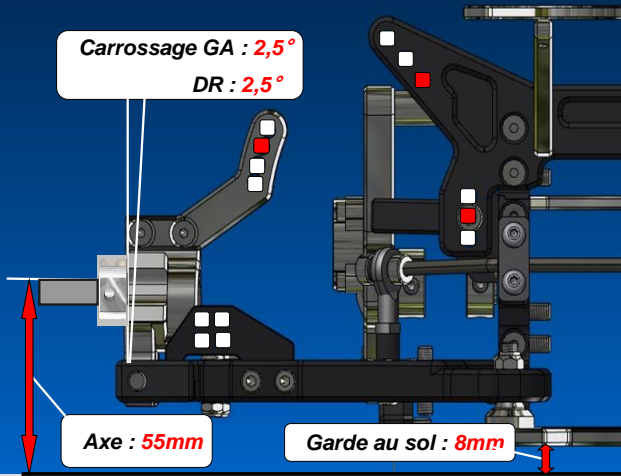

Ressort: **ORANGE**

Huile : **5000**

Nb trous
 Piston : **6**

øTrous
 Piston : **1.2**

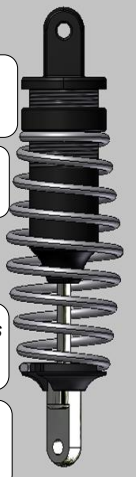

TRAIN AV

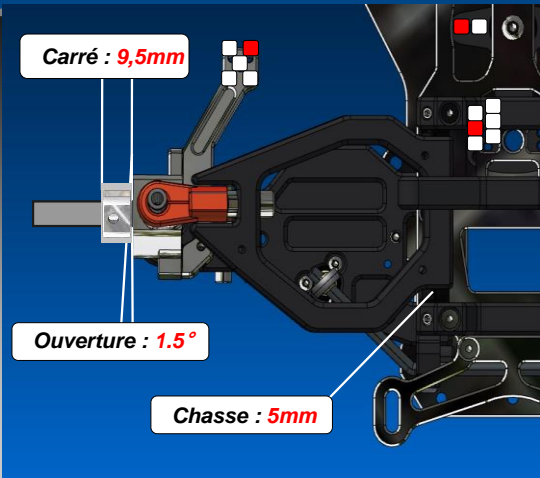
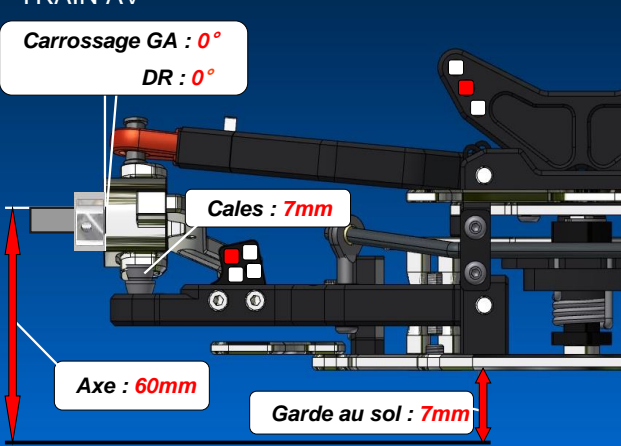

Ressort: **BLANC**

Huile : **6500**

Nb trous
 Piston : **6**

øTrous
 Piston : **1.2**



TRANSMISSION

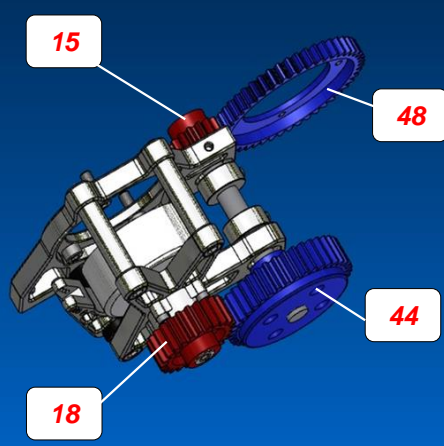

NOTES: